

## FEATURES

- Oil impregnated sintered bronze rod bushing
- Available with magnetic pistons
- 303 stainless steel ground, polished and roller burnished piston rods
- Double acting, spring return, spring extend & double rod cylinders
- 304 stainless steel tube
- Temperature range: 30° F to 180° F
- Anodized aluminum heads
- Air pressure rating to 250 psig

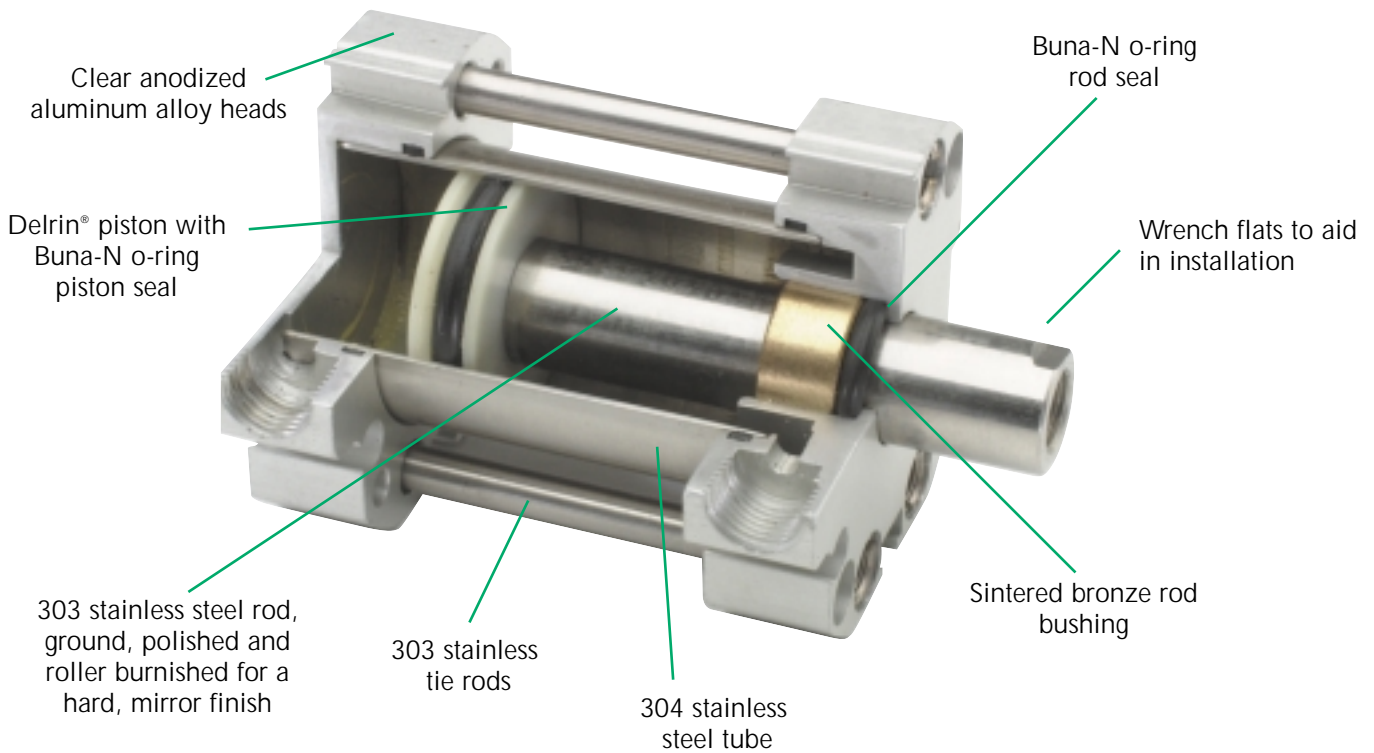

Delrin® is a registered trademark of E.I. DuPont Co.

## NUMBERING SYSTEM

